

PILOTED OPERATED SOLENOID VALVE

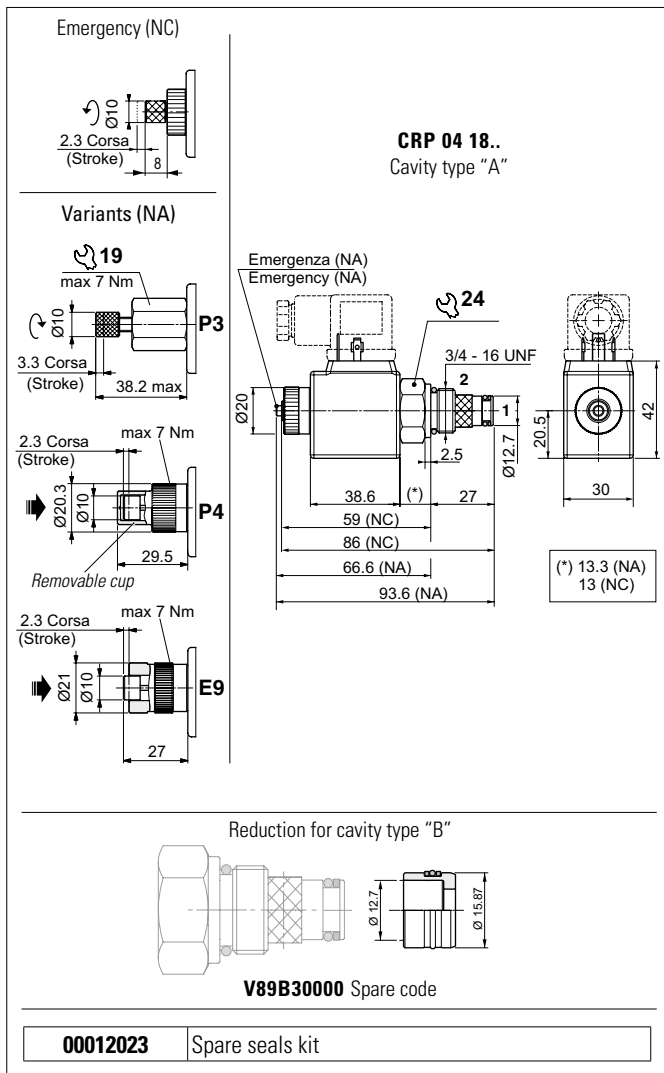

Connector to be ordered separately, see sect. 18

HYDRAULIC SYMBOLS

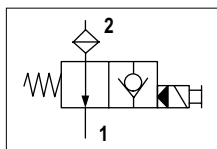

CRP - Normally open

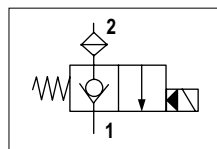

CRP - Normally closed

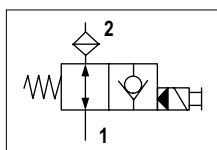

CRB - Normally open

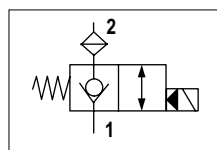

CRB - Normally closed

The pilot-operated electric 2-way 2-position directional valve is controlled electrically.
The tapered poppet is in tempered and ground steel.
Available in normally open (NA) or normally closed (NC) versions.

Valve	Free passage	Coil	Type
CRP..NA	2 → 1	DE-ENERGISED	Unidirectional
CRP..NC	2 → 1 1 → 2	ENERGISED DE-ENERGISED	
CRB..NA	1 → 2 2 → 1	DE-ENERGISED	Bidirectional
CRB..NC	1 → 2 2 → 1	ENERGISED / DE-ENERGISED ENERGISED	

Normally closed valves can work with DC or AC coils.
Normally open valves work with DC coils whereas RAC coils with a connector and incorporated rectifier must be used for AC applications.
The NC valve sleeve is in galvanised steel and the NA valve sleeve with nickel coated.

FEATURES

Max. pressure	300 bar
Max. Flow	40 l/min
Max. Leakage (0 ÷ 10 drops/min)	0 ÷ 0.5 cm ³ /min
Max. excitation frequency	2 Hz
Duty cycle	100% ED
Hydraulic fluids	DIN 51524 Mineral oils
Fluid viscosity	10 ÷ 500 mm ² /s
Fluid temperature	-25°C ÷ 75°C
Ambient temperature	-25°C ÷ 60°C
Max. contamin. level class with filter	ISO 4406:1999 - class 19/17/14
Cartridge filter	280µm
Type of protection (in relation to the connection used)	IP65
Weight (with coil)	0.27 kg
Cartridge tightening torque	25 ÷ 30 Nm
Coil ring nut tightening torque	7 Nm
Emergency tightening torque	
Cavity standard "A" (3/4 - 16 UNF)	CD018006 (See section 15)
Cavity standard "A" + seat VSCOA**01	CD018009 (See section 15)
Cavity with reduction "B" (3/4 - 16 UNF)	CD018012 (See section 15)

PRESSURE DROPS

LIMITS OF USE

CRB..NA (1 → 2 2 → 1)
CRP..NA (2 → 1)

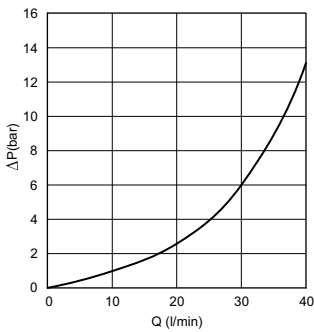

CRB..NC (2 → 1)
CRP..NC (2 → 1)

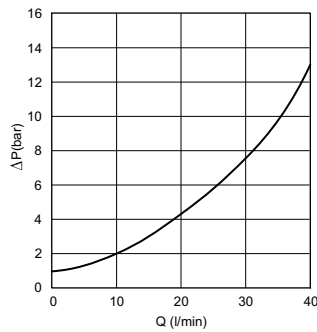

CRB..NC (1 → 2)
CRP..NC (1 → 2)

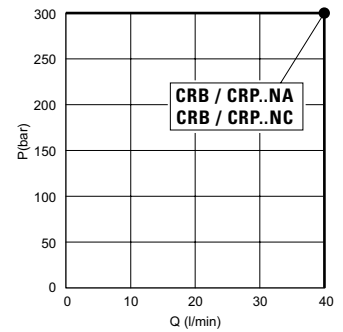
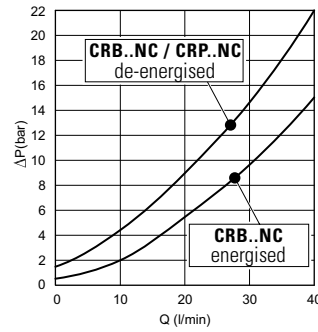

The tests were carried out with the solenoids at operating temperature, with a supply voltage 10% below nominal value and with a 40°C fluid temperature. The fluid used is a mineral oil with viscosity of 46 mm²/s at 40°C.

ORDERING CODE

	CR*	04	18	**	*	*	*	**	*															
	Series	Size	Coil	Version	Seat size	Version	Voltage	Variants																
<p>CRB = Piloted solenoid valve bidirectional</p> <p>CRP = Piloted solenoid valve unidirectional</p>		<p>04 = 3/4 - 16 UNF</p>	<p>18 = 18W dc (NA-NC) - C30</p>	<p>NA = Normally open (solo con bobine DC o RAC)</p> <p>NC = Normally closed</p>	<p>A = Standard - Ø 12.7 mm</p> <p>B = With reduction - Ø 15.9 mm</p>	<p>S = Without emergency (NC)</p> <p>E = With emergency (NA-NC)</p>		<p>00 = No variants</p> <p>P4 = Push button Emergency with removable protection (..NA)</p> <p>P3 = Rotary Emergency (..NA)</p> <p>E9 = Push button Emergency direct control (..NA)</p> <p>SF = Without cartridge filter</p> <p>FK = With flying leads 600 mm (1)</p> <p>CX = Deutsch connection with bidirectional diode (2)</p> <p><i>Connector to be ordered separately, see sect. 18</i></p>	<p>1 = CRB - Serial No.</p> <p>3 = CRP - Serial No.</p>															
							<table border="1" style="width: 100%; border-collapse: collapse;"> <thead> <tr> <th style="text-align: left;">DC 18W (C30)</th> <th style="text-align: left;">AC 18W (C30) (7)</th> </tr> </thead> <tbody> <tr> <td>L = 12 VDC</td> <td>A = 24 VAC 50 Hz</td> </tr> <tr> <td>M = 24 VDC</td> <td>J = 115 VAC 50 Hz</td> </tr> <tr> <td>N = 48 VDC</td> <td>I = 230 VAC 50 Hz</td> </tr> <tr> <td>2 = 21.6 VDC RAC (3)</td> <td>F = 24 VAC 60 Hz</td> </tr> <tr> <td>Z = 102 VDC RAC (4)</td> <td>C = 110 VAC 60 Hz</td> </tr> <tr> <td>X = 205 VDC RAC (5)</td> <td>D = 220 VAC 60 Hz</td> </tr> <tr> <td>W = Without coil (6)</td> <td></td> </tr> </tbody> </table>	DC 18W (C30)	AC 18W (C30) (7)	L = 12 VDC	A = 24 VAC 50 Hz	M = 24 VDC	J = 115 VAC 50 Hz	N = 48 VDC	I = 230 VAC 50 Hz	2 = 21.6 VDC RAC (3)	F = 24 VAC 60 Hz	Z = 102 VDC RAC (4)	C = 110 VAC 60 Hz	X = 205 VDC RAC (5)	D = 220 VAC 60 Hz	W = Without coil (6)		
DC 18W (C30)	AC 18W (C30) (7)																							
L = 12 VDC	A = 24 VAC 50 Hz																							
M = 24 VDC	J = 115 VAC 50 Hz																							
N = 48 VDC	I = 230 VAC 50 Hz																							
2 = 21.6 VDC RAC (3)	F = 24 VAC 60 Hz																							
Z = 102 VDC RAC (4)	C = 110 VAC 60 Hz																							
X = 205 VDC RAC (5)	D = 220 VAC 60 Hz																							
W = Without coil (6)																								
									<p><i>Coils technical data, see sect. 17</i></p>															

<p>(1) Only voltages 12 VDC - 24 VDC</p> <p>(2) Only voltages 12 VDC - 24 VDC</p> <p>(3) With rectifier: 24 VAC/50-60Hz</p> <p>(4) With rectifier: 115 VAC/50Hz - 120VAC/60Hz</p>	<p>(5) With rectifier: 230 VAC/50Hz - 240VAC/60Hz</p> <p>(6) Performance are guaranteed only using valves completed with BFP coil</p> <p>(7) Only for NC valves</p>
---	---

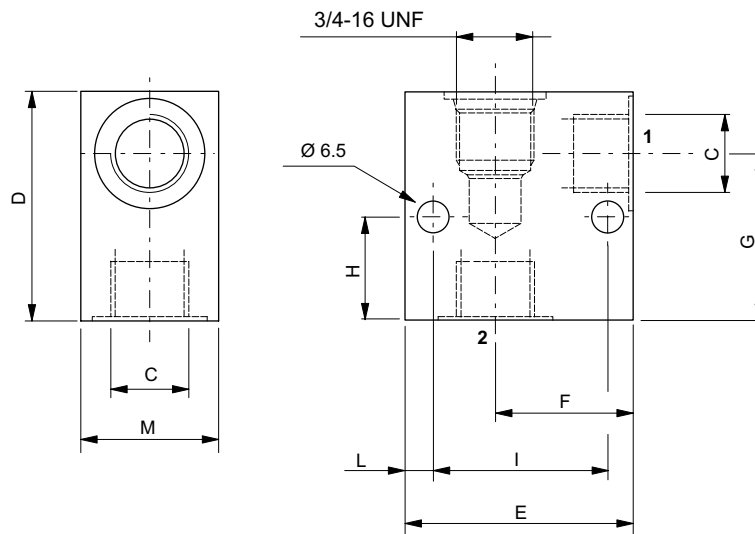

Code	C	D (mm)	E (mm)	F (mm)	G (mm)	H (mm)	I (mm)	L (mm)	M (mm)	Material	Cavity
F07100013	1/4 BSP	46	50	30,5	33	18	38	6	30	Alluminio EN AW 2011	CD018006
M18400061	3/8 BSP	55	60	38	41,25	25	45	7,5	30		
M18400071	1/2 BSP	60	60	35	41	6	48	6	40		

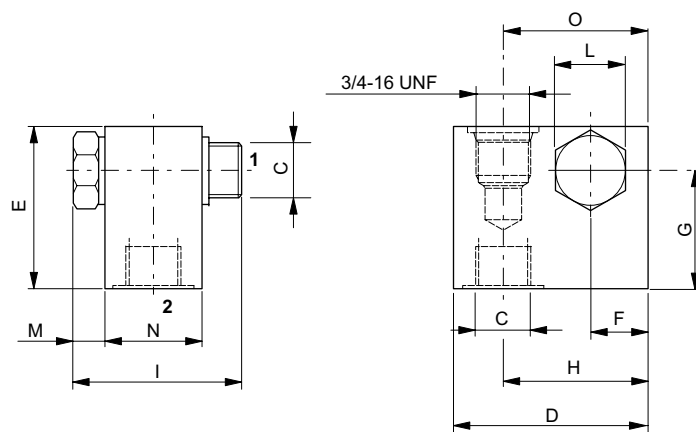

Code	C	D (mm)	E (mm)	F (mm)	G (mm)	H (mm)	I (mm)	L (mm)	M (mm)	N (mm)	O (mm)	Material	Cavity
17030532	3/8 BSP	50	50	16	32	35	51	22	9	30	34.5	Alluminium EN AW 2011	CD018006
V10500034	1/4 BSP	40	46	11	31	26	49	19	8	30	26		

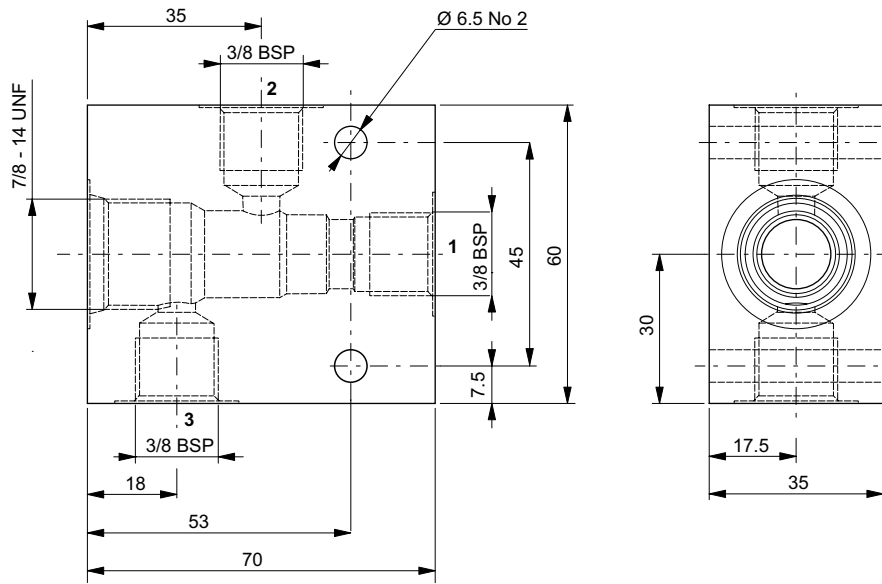

Code	Material	Cavity
M10850319	Alluminium - EN AW 2011	CD019006

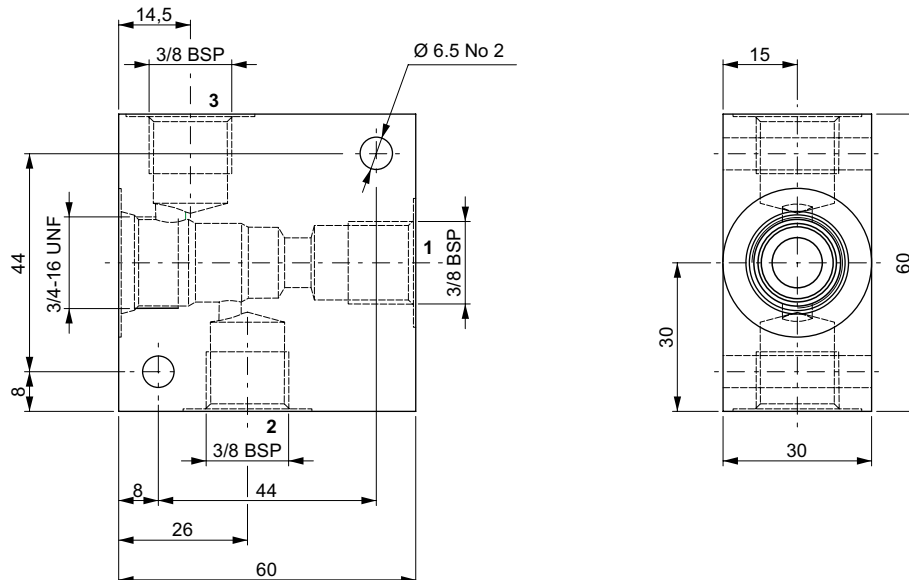

Code	Material	Cavity
M10850206	Alluminium - EN AW 2011	CD018005

CA012001

1/4 BSP

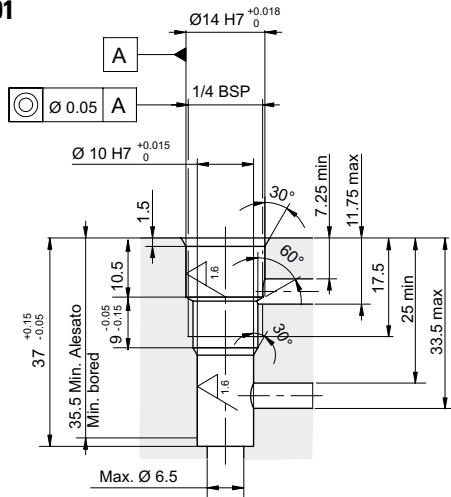

Plugs compatibility:

--	--	--	--	--

CD018001

3/4 16UNF

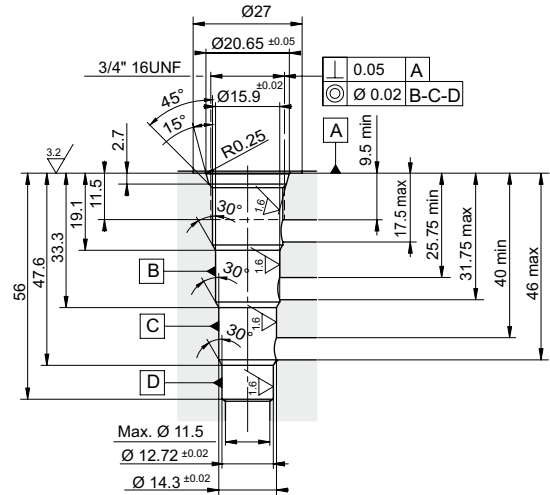

Plugs compatibility:

R78150114	R78150109	R78150111		
-----------	-----------	-----------	--	--

CD018003

3/4 16UNF

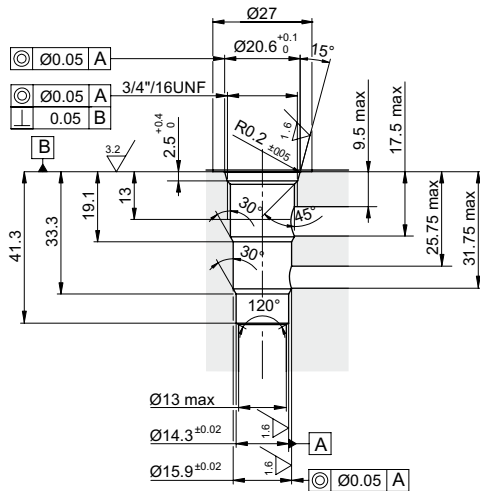

Plugs compatibility:

20001700	20001900			
----------	----------	--	--	--

CD018005

3/4 16UNF

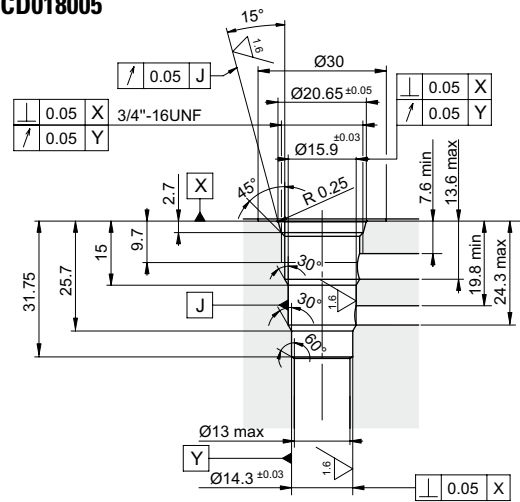

Plugs compatibility:

--	--	--	--	--

CD018006

3/4 16UNF

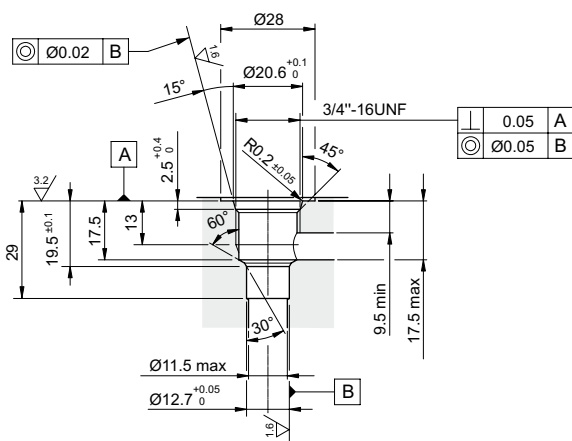

Plugs compatibility:

20001900	20001700	20003800	20009400	20018000
----------	----------	----------	----------	----------

CD018009

3/4 16UNF

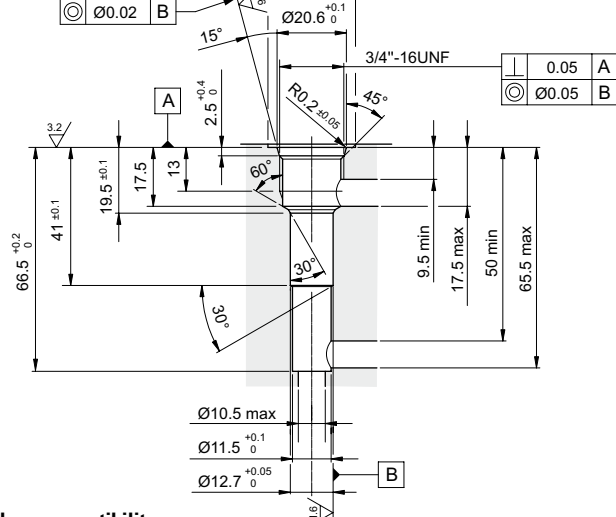

Plugs compatibility:

20001900	20001700	20003800	20009400	20018000
----------	----------	----------	----------	----------

CD018012

3/4 16UNF

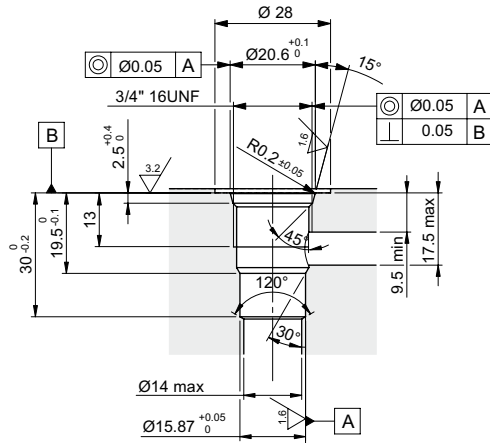

Plugs compatibility:

R78200A19	20001700	20001900		
-----------	----------	----------	--	--

CD018013

3/4 16UNF

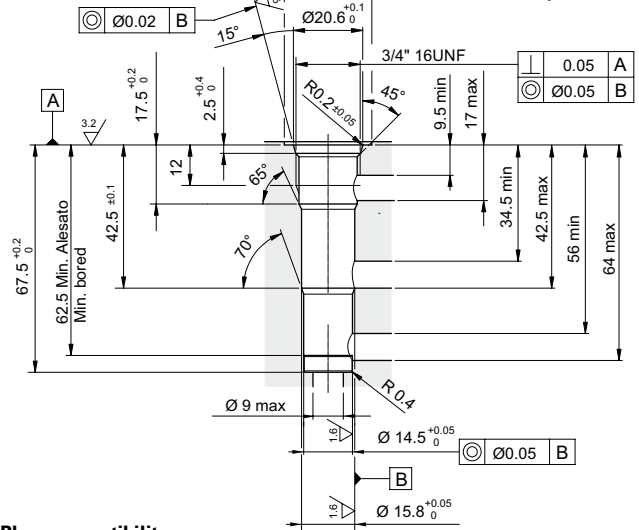

Plugs compatibility:

R78150100				
-----------	--	--	--	--

CD018014

3/4 16UNF

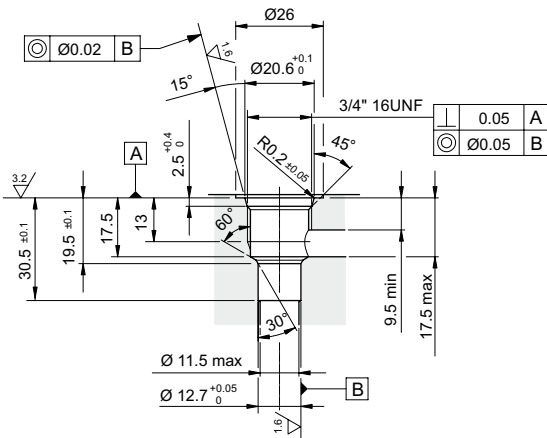

Plugs compatibility:

20001900	20001700	20003800	20009400	20018000
----------	----------	----------	----------	----------

CD018015

3/4 16UNF

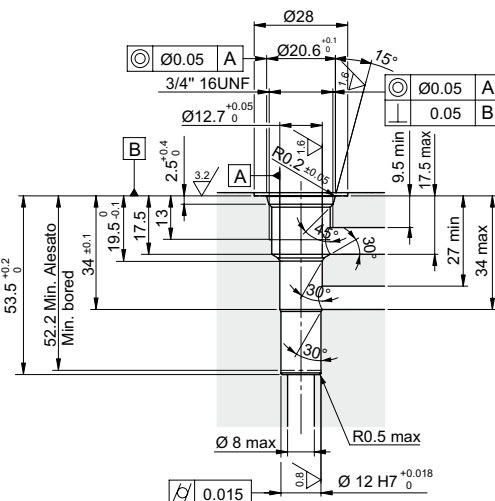

Plugs compatibility:

20018000	20001700	20001900	20003800	20009400
----------	----------	----------	----------	----------

CD018016

3/4 16UNF

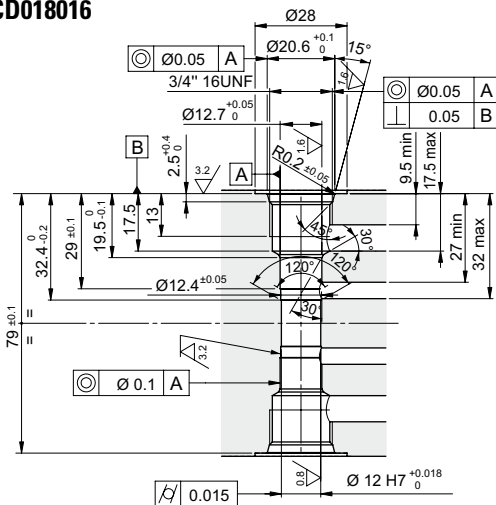

Plugs compatibility:

20018000	20001700	20001900	20003800	20009400
----------	----------	----------	----------	----------

CD019006

7/8 14UNF

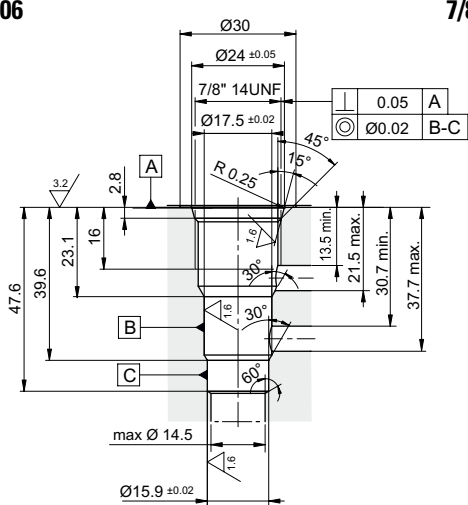

Plugs compatibility:

--	--	--	--	--

CD019007

7/8 14UNF

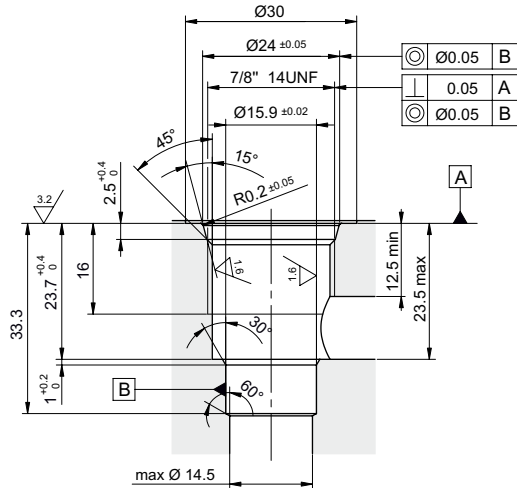

Plugs compatibility:

--	--	--	--	--

CD019011

7/8 14UNF

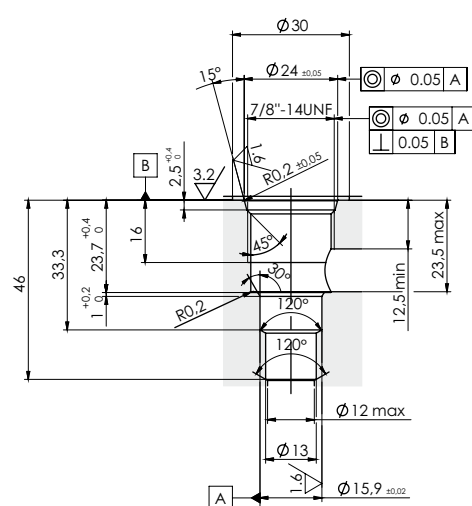

Plugs compatibility:

--	--	--	--	--

CG001002

1/8 BSP

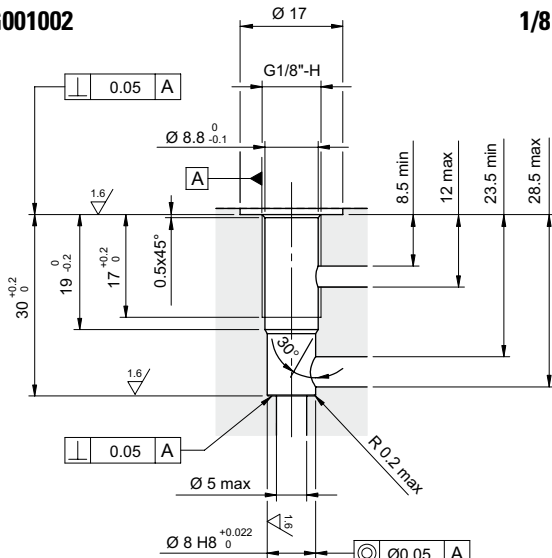

Plugs compatibility:

--	--	--	--	--

CG003004

3/8 BSP

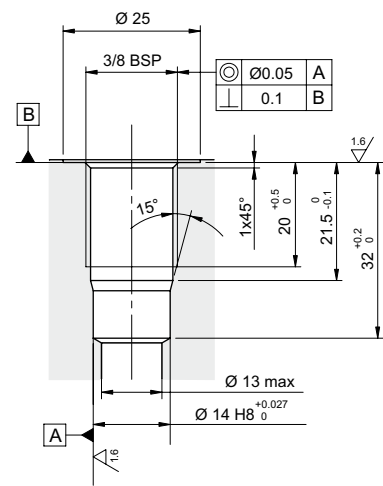

Plugs compatibility:

--	--	--	--	--

CN019002

M10X1

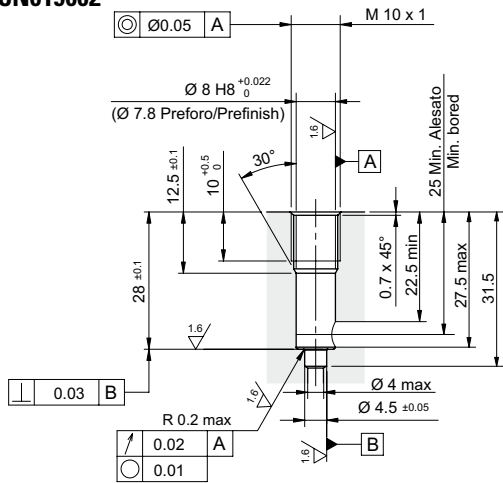

Plugs compatibility:

--	--	--	--	--

CN032005

M14X1.5

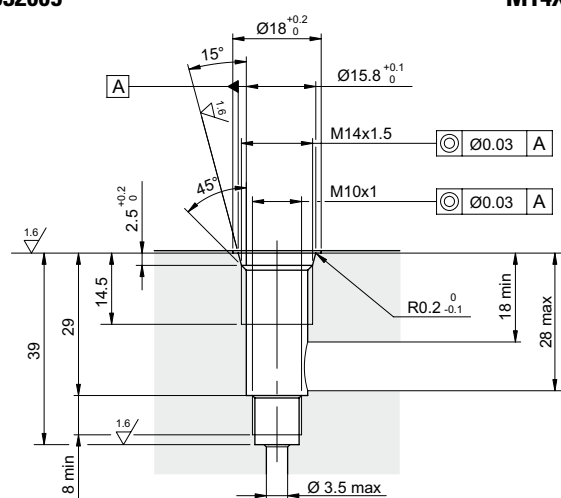

Plugs compatibility:

--	--	--	--	--

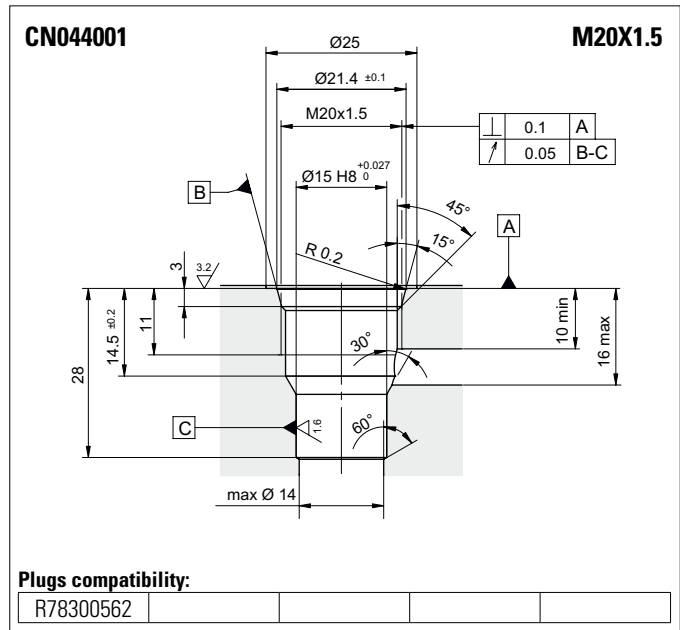
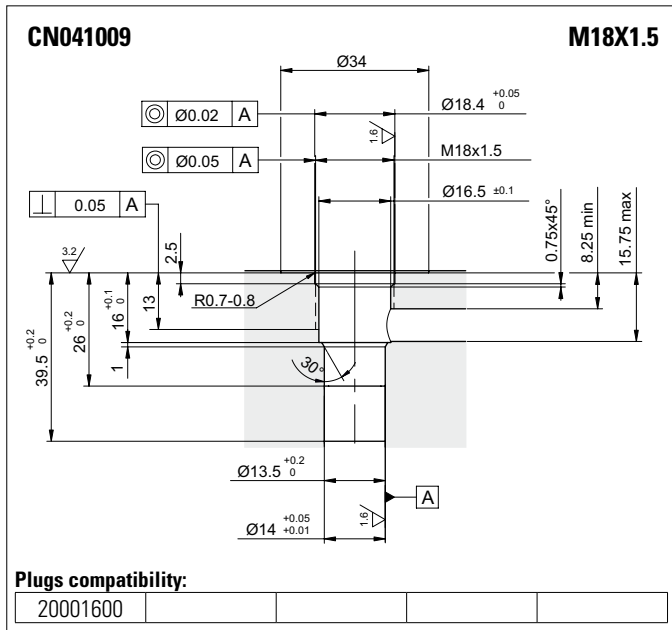
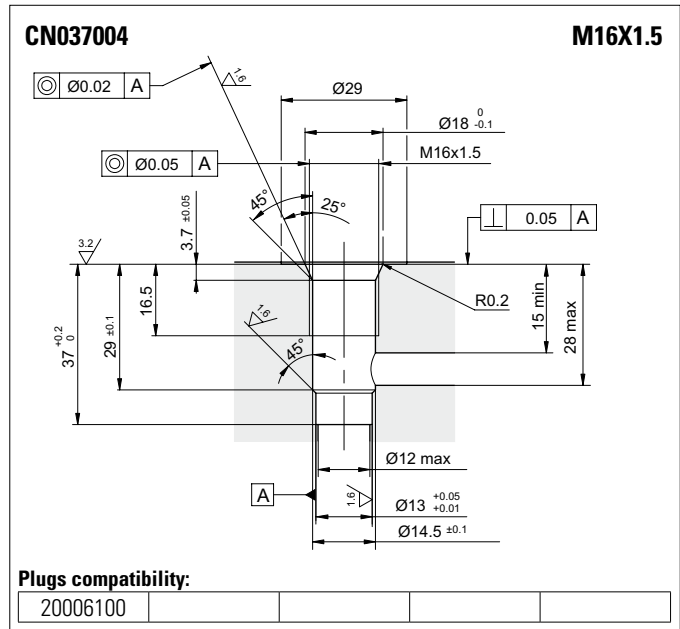
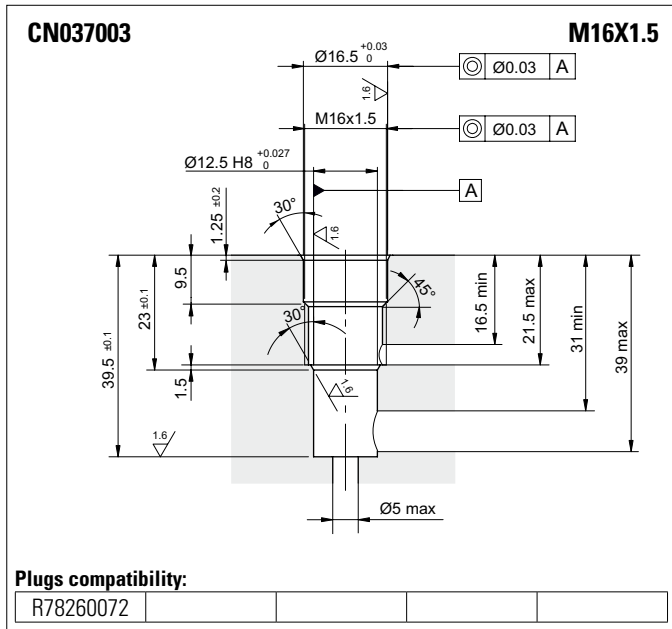
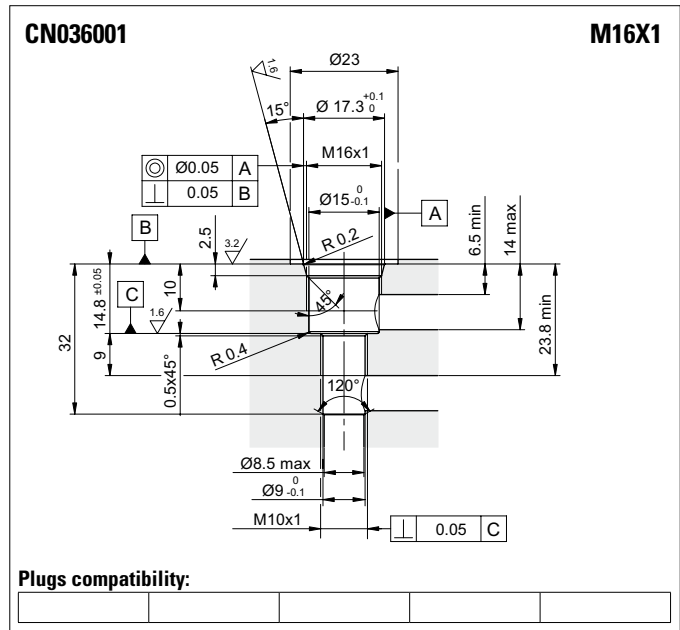
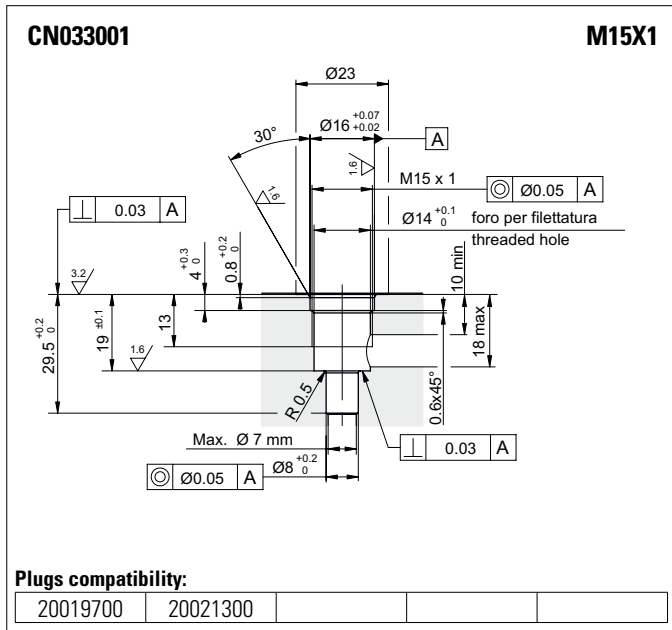

CN047002 **M22X1.5**

Plugs compatibility:

R78050014			
-----------	--	--	--

CN047003 **M22X1.5**

Plugs compatibility:

R78400A17			
-----------	--	--	--

CN051001 **M24X2**

Plugs compatibility:

R78300564			
-----------	--	--	--

CN059001 **M27X1.5**

Plugs compatibility:

--	--	--	--

CN070001 **M33X2**

Plugs compatibility:

R78400568			
-----------	--	--	--

Plugs compatibility:

--	--	--	--

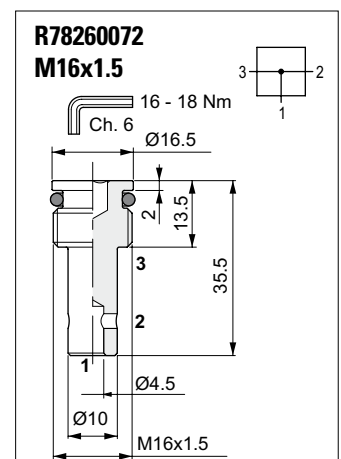
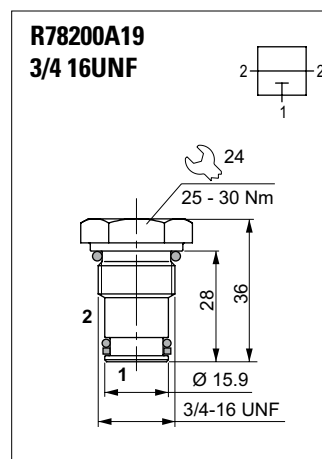
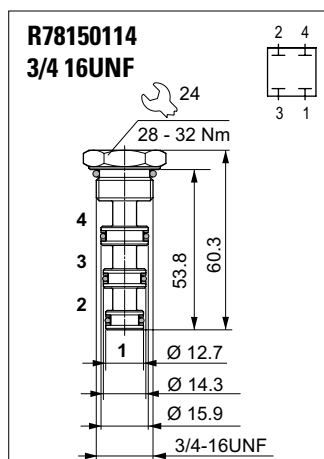
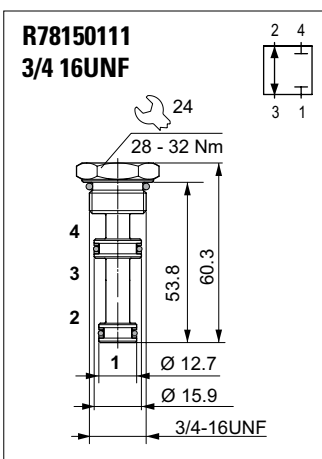
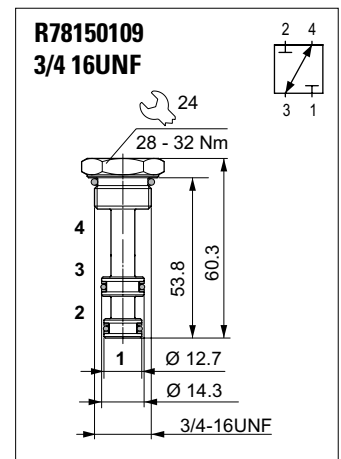
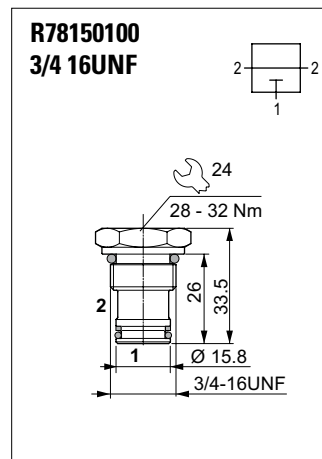
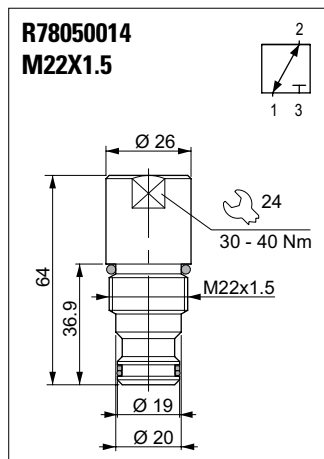
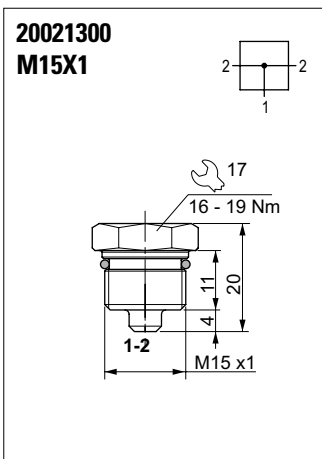
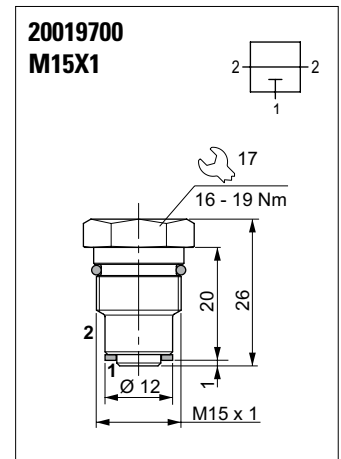
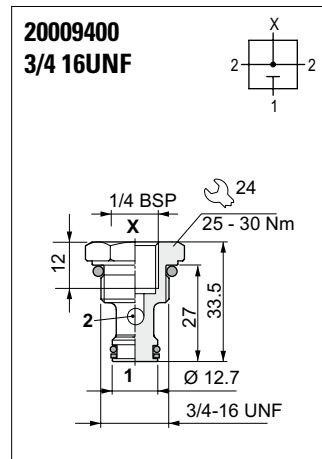
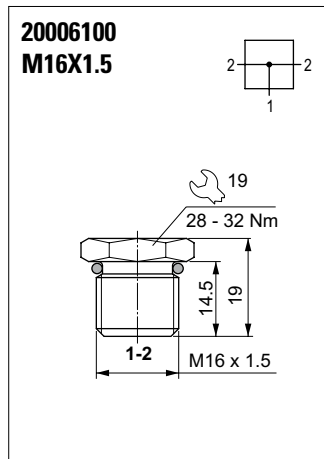
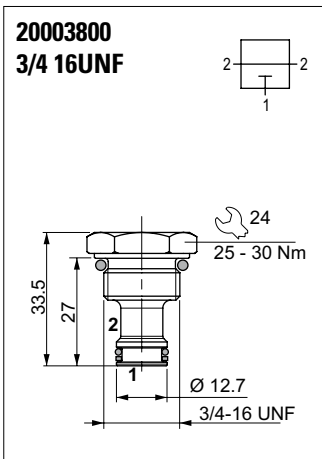
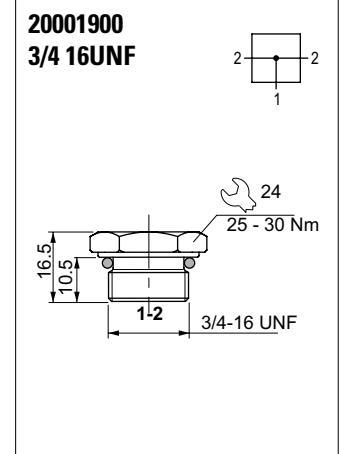
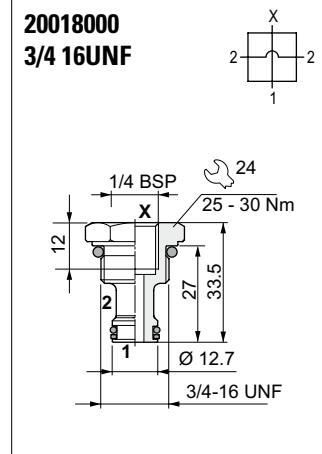
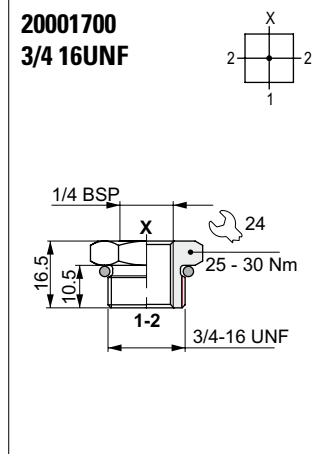
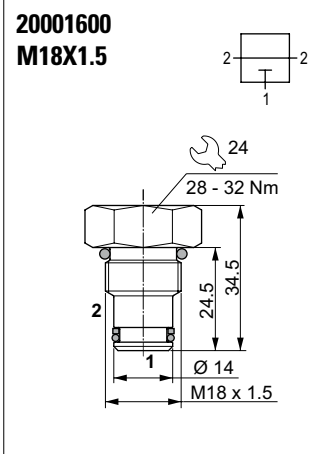

STANDARD PLUGS

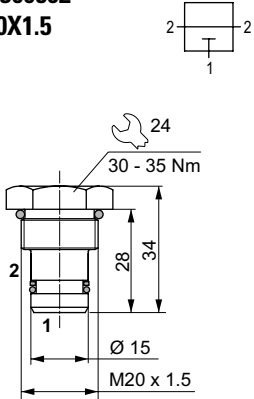
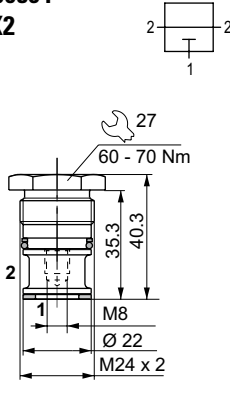
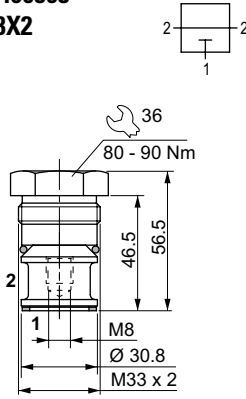
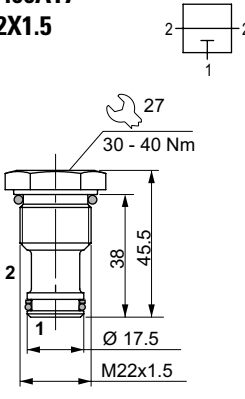
<p>R78300562 M20X1.5</p> 	<p>R78300564 M24X2</p> 	<p>R78400568 M33X2</p> 	<p>R78400A17 M22X1.5</p> 

C30 - COILS 18W

Type of protection	IP 65
Number of cycle	18000/h
Supply tolerance	±10%
Ambient temperature	-30°C ÷ 60°C

Duty cycle	100% ED
Insulation class wire	H
Weight	0.141 kg

Standard (Hirschmann ISO 4400 DIN43650)

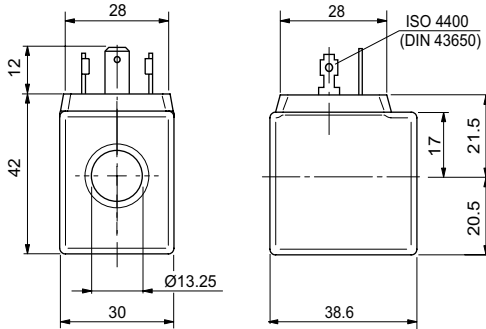

Coil		Max winding temperature (1)	Rated power	Resistance ±7% (2)	Spare code
Code	Voltage				
L	12 VDC	135 °C	18 W	7.7 Ω	M14000001
M	24 VDC	135 °C	18 W	31 Ω	M14000002
N	48 VDC	135 °C	18 W	116 Ω	M14000003
2	21.6 VDC	135 °C	18 W	27 Ω	M14000009
Z	102 VDC (3)	120 °C	18 W	578 Ω	M14000006
X	205 VDC (3)	120 °C	18 W	2627 Ω	M14000007
A	24 VAC/50 Hz	125 °C	35 VA	5.3 Ω	M14001002
J	115 VAC/50 Hz (3)	125 °C	35 VA	108 Ω	M14001004
I	230 VAC/50 Hz (3)	125 °C	35 VA	438 Ω	M14001005
F	24 VAC/60 Hz	125 °C	35 VA	3.8 Ω	M14001012
C	110 VAC/60 Hz (3)	125 °C	35 VA	92 Ω	M14001014
D	220 VAC/60 Hz (3)	125 °C	35 VA	375 Ω	M14001015

(1) Ambient temperature 25 °C - (2) Ambient temperature 20 °C

(3) The european low voltage directive is applied to electronical equipments used at a nominal voltages between 50 and 1000 VAC or 75 and 1500 VDC. In conformity with the low directive each part of the manifold or the subplate on which the valve is mounted should be connected to a protective earth with a resistance less than 0.1 ohms.

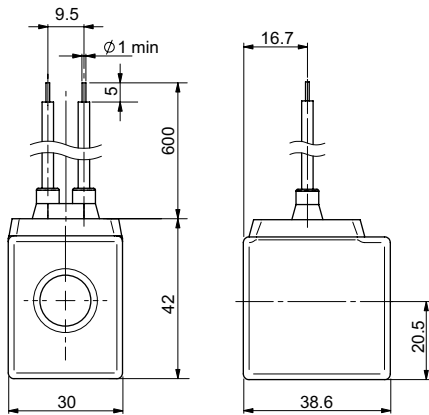

With wires (variant FK)

Coil		Max winding temperature (1)	Rated power	Resistance ±7% (2)	Spare code
Code	Voltage				
L	12 VDC	135 °C	18 W	7.7 Ω	M14000101
M	24 VDC	135 °C	18 W	31 Ω	M14000102

(1) Ambient temperature 25 °C - (2) Ambient temperature 20 °C

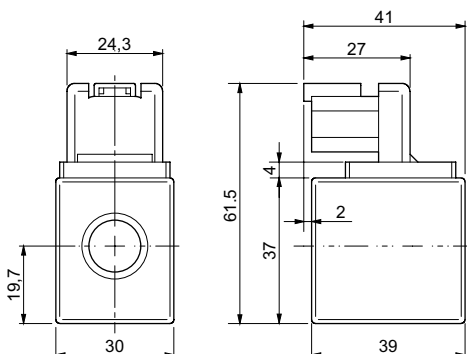

DEUTSCH and bidirectional integrated diode (variant CX)

Coil		Max winding temperature (1)	Rated power	Resistance ±7% (2)	Spare code
Code	Voltage				
L	12 VDC	135 °C	18 W	7.7 Ω	M14760001
M	24 VDC	135 °C	18 W	31 Ω	M14760002

(1) Ambient temperature 25 °C - (2) Ambient temperature 20 °C

C36 - COILS 22W

Type of protection	IP 65
Number of cycle	18000/h
Supply tolerance	±10%
Ambient temperature	-30°C ÷ 60°C

Duty cycle	100% ED
Insulation class wire	H
Weight	0.2 kg

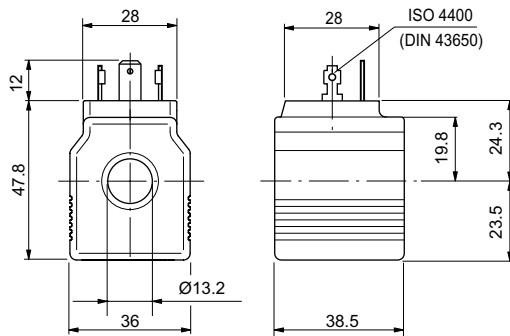

Standard (Hirschmann ISO 4400 DIN43650)

Coil		Max winding temperature (1)	Rated power	Resistance ±7% (2)	Spare code
Code	Voltage				
L	12 VDC	135 °C	22 W	6.3 Ω	M14040001
4	14 VDC	135 °C	22 W	8.9 Ω	M14040009
M	24 VDC	135 °C	22 W	25.6 Ω	M14040002
V	28 VDC	135 °C	22 W	32.8 Ω	M14040008
N	48 VDC	135 °C	22 W	102 Ω	M14040003
2	21.6 VDC	135 °C	22 W	20.2 Ω	M14040000
Z	102 VDC (3)	135 °C	22 W	467.85 Ω	M14040006
X	205 VDC (3)	135 °C	22 W	1954 Ω	M14040007

(1) Ambient temperature 25 °C - (2) Ambient temperature 20 °C

(3) The european low voltage directive is applied to electronical equipments used at a nominal voltages between 50 and 1000 VAC or 75 and 1500 VDC. In conformity with the low directive each part of the manifold or the subplate on which the valve is mounted should be connected to a protective earth with a resistance less than 0.1 ohms.

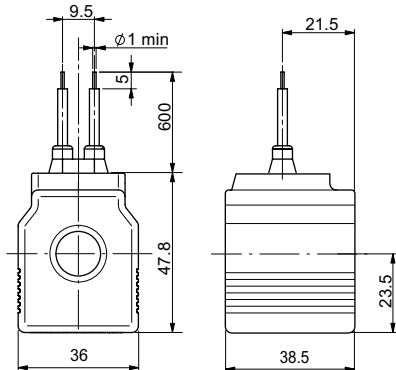

With wires (variant FK)

Coil		Max winding temperature (1)	Rated power	Resistance ±7% (2)	Spare code
Code	Voltage				
L	12 VDC	135 °C	22 W	6.3 Ω	M14040101
4	14 VDC	135 °C	22 W	8.9 Ω	M14040109
M	24 VDC	135 °C	22 W	25.6 Ω	M14040102
V	28 VDC	135 °C	22 W	32.8 Ω	M14040108

(1) Ambient temperature 25 °C - (2) Ambient temperature 20 °C

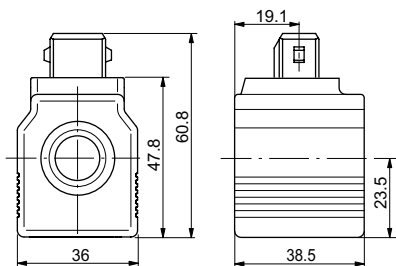

AMP Junior (variant AJ)

Coil		Max winding temperature (1)	Rated power	Resistance ±7% (2)	Spare code
Code	Voltage				
L	12 VDC	135 °C	22 W	6.3 Ω	M14730001
M	24 VDC	135 °C	22 W	25.6 Ω	M14730002

(1) Ambient temperature 25 °C - (2) Ambient temperature 20 °C

A09 - COILS 27W

Type of protection	IP 65
Number of cycle	18000/h
Supply tolerance	±10%
Ambient temperature	-30°C ÷ 60°C

Duty cycle	100% ED
Insulation class wire	H
Weight	0.215 kg

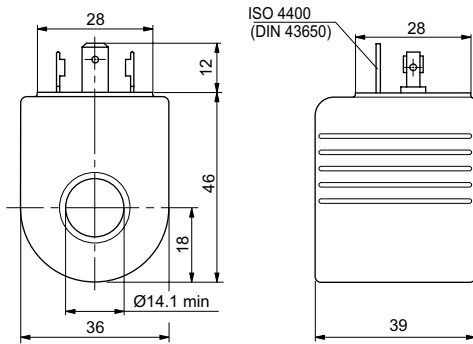

Hirschmann ISO 4400 DIN43650 (connection H)

Coil		Max winding temperature (1)	Rated power	Resistance ±7% (2)	Spare code
Code	Voltage				
L	12 VDC	123 °C	27 W	5.3 Ω	M14310001
M	24 VDC	123 °C	27 W	21.3 Ω	M14310002
N	48 VDC	123 °C	27 W	85.3 Ω	M14310003
Z	102 VDC (3)	123 °C	27 W	392 Ω	M14310008
P	110 VDC (3)	123 °C	27 W	448 Ω	M14310005
X	205 VDC (3)	123 °C	27 W	1577 Ω	M14310009

(1) Ambient temperature 25 °C - (2) Ambient temperature 20 °C

(3) The european low voltage directive is applied to electronical equipments used at a nominal voltages between 50 and 1000 VAC or 75 and 1500 VDC. In conformity with the low directive each part of the manifold or the subplate on which the valve is mounted should be connected to a protective earth with a resistance less than 0.1 ohms.

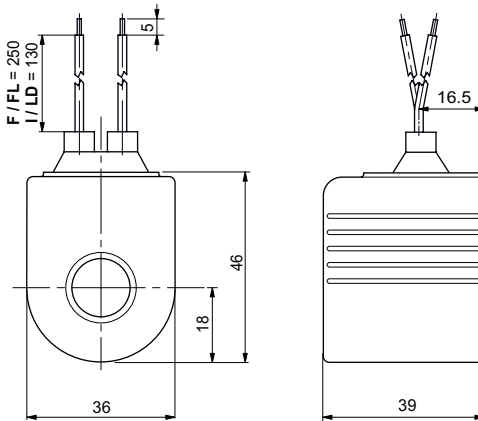

With wires and integrated bidirectional diode (connection F-I / variants FL-LD)

Bobina		Wires (mm)	Max winding temperature (1)	Rated power	Resistance ±7% (2)	Spare code
Codice	Tensione					
L	12 VDC	F = 250	123 °C	27 W	5.3 Ω	M14070011
M	24 VDC	F = 250	123 °C	27 W	21.3 Ω	M14070012
L	12 VDC	I = 130	123 °C	27 W	5.3 Ω	M14330001
M	24 VDC	I = 130	123 °C	27 W	21.3 Ω	M14330002

(1) Ambient temperature 25 °C - (2) Ambient temperature 20 °C

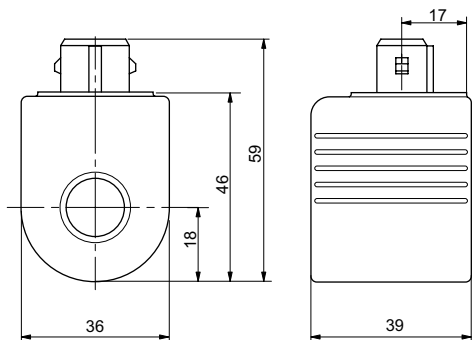

AMP Junior (connection A / variant AJ)

Coil		Max winding temperature (1)	Rated power	Resistance ±7% (2)	Spare code
Code	Voltage				
L	12 VDC	123 °C	27 W	5.3 Ω	M14320001
M	24 VDC	123 °C	27 W	21.3 Ω	M14320002

(1) Ambient temperature 25 °C - (2) Ambient temperature 20 °C

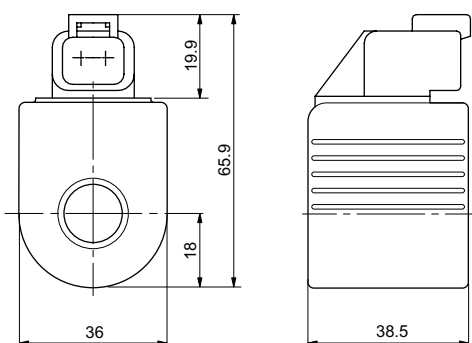

Deutsch + bidirectional diode - DT04-2P (connection D / variant CX)

Coil		Max winding temperature (1)	Rated power	Resistance ±7% (2)	Spare code
Code	Voltage				
L	12 VDC	123 °C	27 W	5.3 Ω	M14340001
M	24 VDC	123 °C	27 W	21.3 Ω	M14340002

(1) Ambient temperature 25 °C - (2) Ambient temperature 20 °C

D12 - COILS 30W

Type of protection	IP 65
Number of cycle	18000/h
Supply tolerance	±10%
Ambient temperature	-30°C ÷ 60°C

Duty cycle	100% ED
Insulation class wire	H
Weight	0.2 kg

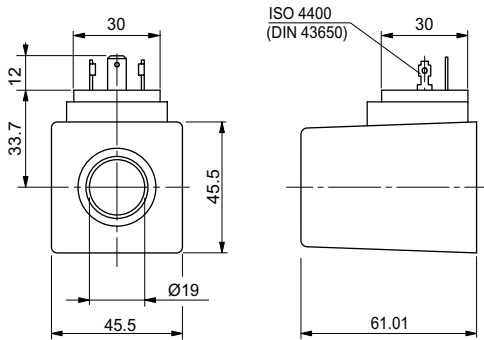

Standard (Hirschmann ISO 4400 DIN43650)

Coil		Max winding temperature (1)	Rated power	Resistance ±7% (2)	Spare code
Code	Voltage				
L	12 VDC	108 °C	30 W	4.7 Ω	M14100010
M	24 VDC	108 °C	30 W	18.8 Ω	M14100011

(1) Ambient temperature 25 °C - (2) Ambient temperature 20 °C

CONNECTORS FOR CONTROL VALVES IN ACCORDANCE WITH DIN 43650 / ISO 4400

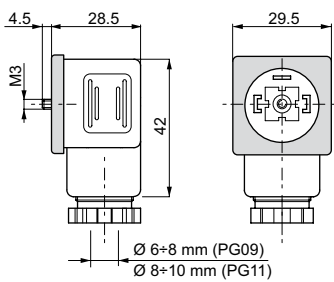

Connector	Protection level	Type	Cable gland	Code
Standard	IP65	Black color	PG09	V86 05 0002
		Grey color	PG09	V86 05 0004
		Black color	PG11	V86 05 0006
		Grey color	PG11	V86 05 0008
Lens cover with pilot light (1)	IP65	12 VAC/VDC	PG09	V86 10 0018
		24 VAC/VDC	PG09	V86 10 0012
		115 VAC/VDC	PG09	V86 10 0020
		230 VAC/VDC	PG09	V86 10 0022

(1) do not use for proportional versions

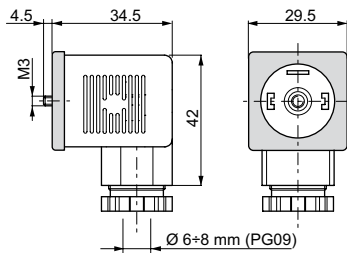

Connector	Protection level	Type	Cable gland	Code
With rectifier (1) Inlet voltage 12÷230 VAC Outlet voltage 9÷205 VDC	IP65	Black color	PG09	V86 20 0002
		Grey color	PG09	V86 20 0004
Lens cover with pilot light and rectifier (1) Inlet voltage 12÷230 VAC Outlet voltage 9÷205 VDC	IP65	12 VAC	PG09	V86 25 0018
		24 VAC	PG09	V86 25 0019
		48 VAC	PG09	V86 25 0020
		115 VAC	PG09	V86 25 0021
		230 VAC	PG09	V86 25 0022

(1) do not use for proportional versions

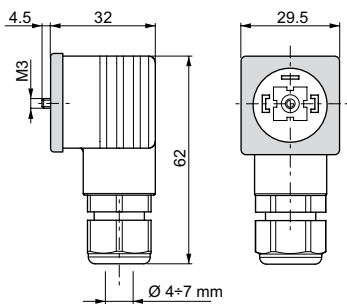

Connector	Protection level	Type	Cable gland	Code
With protection level IP67	IP67	Black color	—	V86 28 0001
		Grey color	—	V86 28 0002

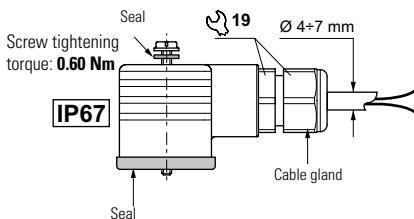
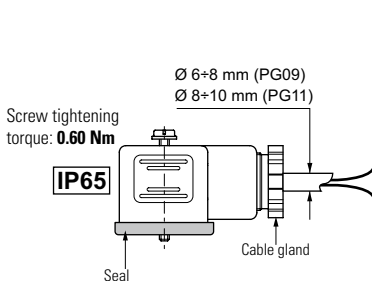

Electrical features of connectors

Description	IP65	IP67
AC rated voltage	Max. 250 V	Max. 250 V
DC rated voltage	Max. 300 V	Max. 300 V
Pin contact nominal current	10A	10A
Pin contact max. current	16A	16A
Max. section cable	1.5 mm ²	1.5 mm ²
Cable gland PG09 - M16x1,5	Ø cable 6 ÷ 8 mm	Ø cable 4 ÷ 7 mm
Cable gland PG11 - G 1/2" - M20x1,5	Ø cable 8 ÷ 10 mm	—
Protection level	IP65 EN60529	IP67 EN60529
Insulation class	VDE 0110-1/89	VDE 0110-1/89
Operating temperature	-40°C ÷ 90°C	-20°C ÷ 80°C

The degrees of protection indicate is guaranteed only if the connectors were properly mounted with his original seals.

Electrical circuits

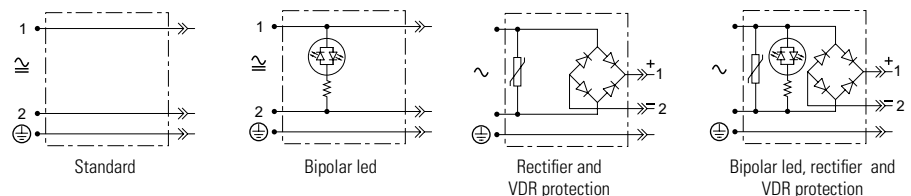

AMP JUNIOR CONNECTORS

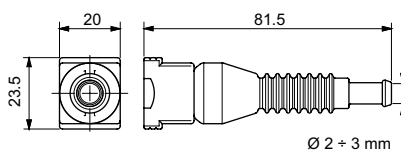

Connector	Type	Cable section	Pin contact max current	Code
AMP Junior connector Timer 2 contact	Black color	0,5 ÷ 1,5 mm ²	10A	RKRC0808000